

MERILO

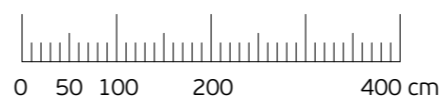

Komercialna skica in vrisana stanovanjska oprema sta informativne narave. Investitor si pridruzuje pravico do sprememb, ki ne vplivajo na funkcionalnost stanovanj.

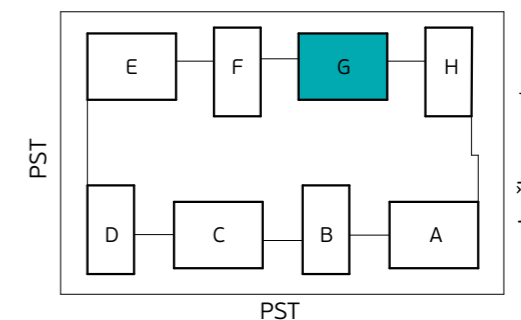

Skica naselja

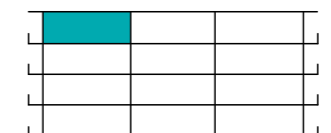

Položaj stanovanja v stavbi - prerez

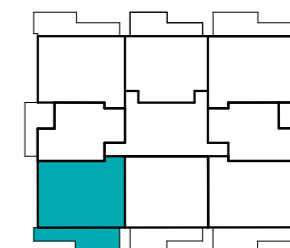

Položaj stanovanja v nadstropju - tloris

STAVBA "G" - 3. NADSTROPJE

STANOVANJE G-3-3

1. PREDPROSTOR	6.2 m ²
2. BIVALNI PROSTOR	33.6 m ²
3. SPALNICA	12.1 m ²
4. KABINET	9.8 m ²
5. KOPALNICA	5.1 m ²
6. WC IN UTILITY	3.1 m ²

STANOVANJSKA POVRŠINA **69.9 m²**

7. TERASA (NADKRITA)	17.5 m ²
8. SHRAMBA ZA KOLESA	4.2 m ²

SKUPNA POVRŠINA **91.6 m²**

PARKIRNO MESTO 1 PM

VIŠEČI VRTOVI 4.2 m²



PRVA HIŠA

Družba za razvoj nepremičninskih projektov

INVESTITOR: **JURČKOVO NASELJE d.o.o.**

PRODAJALEC: **PRVA HIŠA d.o.o.**

Bravničarjeva ulica 13, 1000 Ljubljana

+386 (0)1 292 65 00

info@prvahisa.si

www.jurckovo-naselje.si