

Orientacija stanovanja

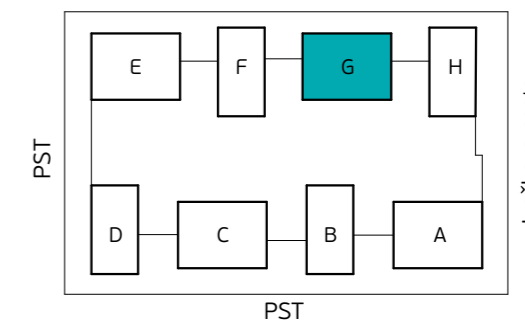

Skica naselja

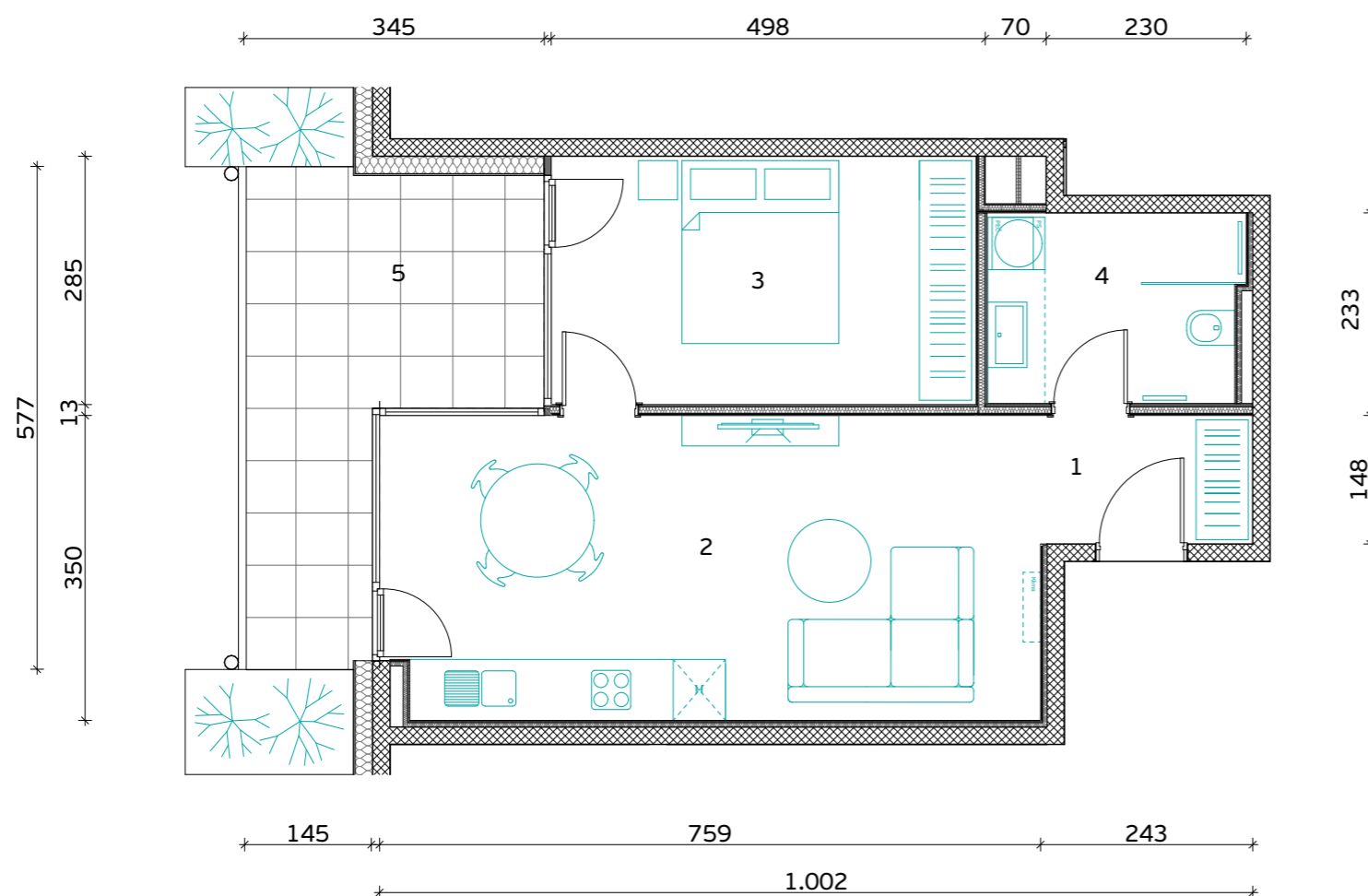
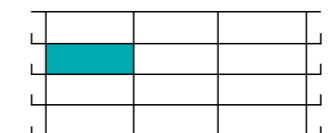

Položaj stanovanja v stavbi - prerez

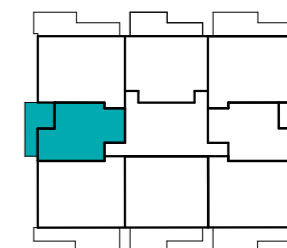

Položaj stanovanja v nadstropju - tloris

**STAVBA "G" - 2. NADSTROPJE**

**STANOVANJE G-2-4**

1. PREDPROSTOR	3.6 m <sup>2</sup>
2. BIVALNI PROSTOR	26.1 m <sup>2</sup>
3. SPALNICA	14.0 m <sup>2</sup>
4. KOPALNICA	6.5 m <sup>2</sup>

**STANOVANJSKA POVRŠINA 50.2 m<sup>2</sup>**

5. TERASA (NADKRITA)	13.3 m <sup>2</sup>
6. SHRAMBA ZA KOLESARJE	3.2 m <sup>2</sup>

**SKUPNA POVRŠINA 66.7 m<sup>2</sup>**

PARKIRNO MESTO 1 PM

VIŠEČI VRTOVI 4.1 m<sup>2</sup>



**PRVAHIŠA**

Družba za razvoj nepremičninskih projektov

INVESTITOR: **JURČKOVO NASELJE d.o.o.**

PRODAJALEC: **PRVA HIŠA d.o.o.**

Bravničarjeva ulica 13, 1000 Ljubljana

+386 (0)1 292 65 00

info@prvahisa.si

www.jurckovo-naselje.si

MERILO

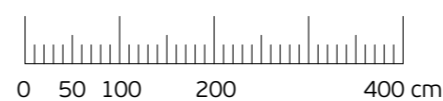

Komercialna skica in vrisana stanovanjska oprema sta informativne narave. Investitor si pridržuje pravico do sprememb, ki ne vplivajo na funkcionalnost stanovanj.