

MERILO

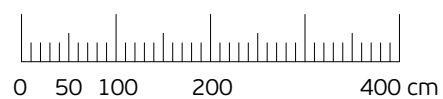

Komercialna skica in vrisana stanovanjska oprema sta informativne narave. Investitor si pridruzuje pravico do sprememb, ki ne vplivajo na funkcionalnost stanovanj.

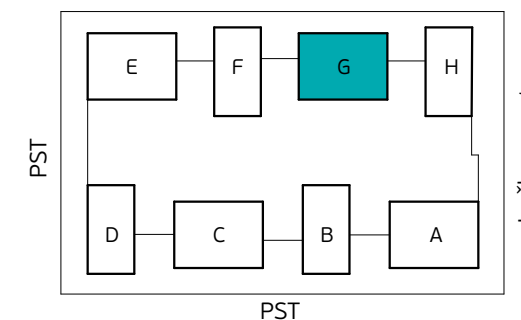

Skica naselja

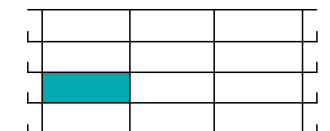

Položaj stanovanja v stavbi - prerez

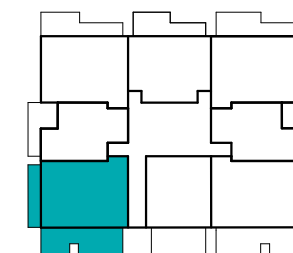

Položaj stanovanja v nadstropju - tloris

STAVBA "G" - 1. NADSTROPJE

STANOVANJE G-1-3

1. PREDPROSTOR	6.2 m ²
2. BIVALNI PROSTOR	33.6 m ²
3. SPALNICA	12.1 m ²
4. KABINET	9.8 m ²
5. KOPALNICA	5.1 m ²
6. WC IN UTILITY	3.1 m ²

STANOVANJSKA POVRŠINA 69.9 m²

7. TERASA (NADKRITA)	17.5 m ²
8. TERASA	12.3 m ²
9. SHRAMBA ZA KOLESA	4.4 m ²

SKUPNA POVRŠINA 104.1 m²

PARKIRNO MESTO 1 PM

VIŠEČI VRTOVI 7.5 m²



PRVAHIŠA

Družba za razvoj nepremičninskih projektov

INVESTITOR: **JURČKOVO NASELJE d.o.o.**

PRODAJALEC: **PRVA HIŠA d.o.o.**

Bravničarjeva ulica 13, 1000 Ljubljana

+386 (0)1 292 65 00

info@prvahisa.si

www.jurckovo-naselje.si