

MERILO

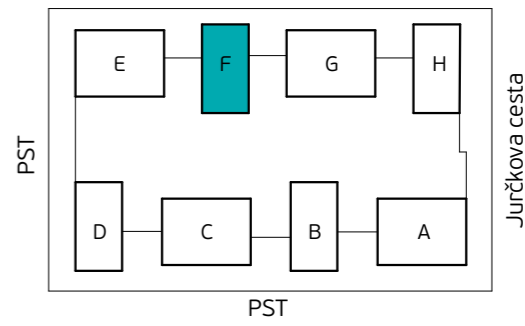

Skica naselja

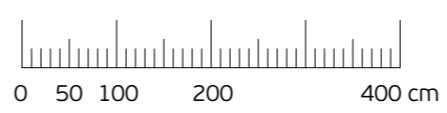
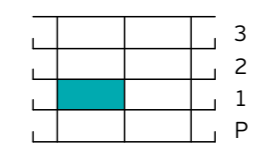

Položaj stanovanja v stavbi - prerez

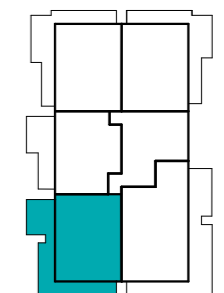

Položaj stanovanja v nadstropju - tloris

STAVBA "F" - 1. NADSTROPJE
STANOVANJE F-1-2

1. PREDPROSTOR	6.8 m ²
2. BIVALNI PROSTOR	35.5 m ²
3. SPALNICA	12.4 m ²
4. KABINET	9.5 m ²
5. KOPALNICA	5.6 m ²

STANOVANJSKA POVRŠINA 69.8 m²

6. TERASA (NADKRITA)	28.0 m ²
6. TERASA	5.0 m ²
7. SHRAMBA ZA KOLESA	4.8 m ²

SKUPNA POVRŠINA 107.6 m²

PARKIRNO MESTO 1 PM

VIŠEČI VRTOVI 8.5 m²



PRVAHIŠA
Družba za razvoj nepremičninskih projektov

INVESTITOR: **JURČKOVO NASELJE d.o.o.**
PRODAJALEC: **PRVA HIŠA d.o.o.**
Bravničarjeva ulica 13, 1000 Ljubljana
+386 (0)1 292 65 00
info@prvahisa.si
www.jurckovo-naselje.si

Komercialna skica in vrisana stanovanjska oprema sta informativne narave. Investitor si pridržuje pravico do sprememb, ki ne vplivajo na funkcionalnost stanovanj.