

Komercialna skica in vrisana stanovanjska oprema sta informativne narave. Investitor si pridruzuje pravico do sprememb, ki ne vplivajo na funkcionalnost stanovanj.

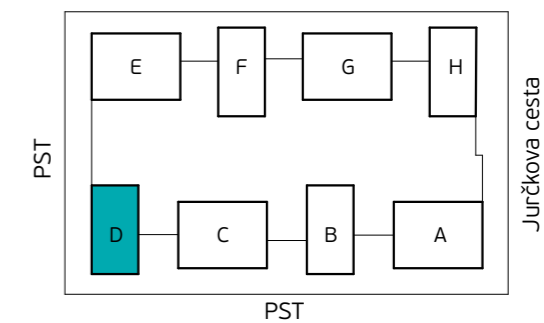

Skica naselja

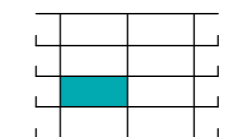

Položaj stanovanja v stavbi - prerez

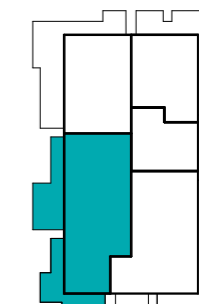

Položaj stanovanja v nadstropju - tloris

STAVBA "D" - 1. NADSTROPJE

STANOVANJE D-1-2

1. PREDPROSTOR	6.8 m ²
2. BIVALNI PROSTOR	55.7 m ²
3. SPALNICA	14.6 m ²
4. KABINET 1	12.0 m ²
5. KABINET 2	13.8 m ²
6. KOPALNICA 1	5.6 m ²
7. KOPALNICA 2	5.1 m ²
8. WC IN UTILITY	5.1 m ²

STANOVANJSKA POVRŠINA **118.7 m²**

9. TERASA (NADKRITA)	43.8 m ²
10. SHRAMBA ZA KOLESA	8.0 m ²

SKUPNA POVRŠINA **170.5 m²**

PARKIRNO MESTO 2 PM

VISEČI VRTOVI 12.8 m²



PRVAHIŠA

Družba za razvoj nepremičninskih projektov

INVESTITOR: **JURČKOVO NASELJE d.o.o.**

PRODAJALEC: **PRVA HIŠA d.o.o.**

Bravničarjeva ulica 13, 1000 Ljubljana

+386 (0)1 292 65 00

info@prvahisa.si

www.jurckovo-naselje.si