

Orientacija stanovanja

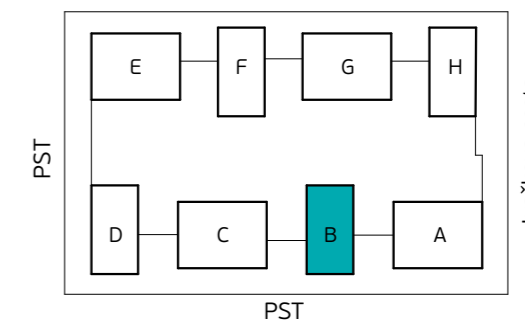

Skica naselja

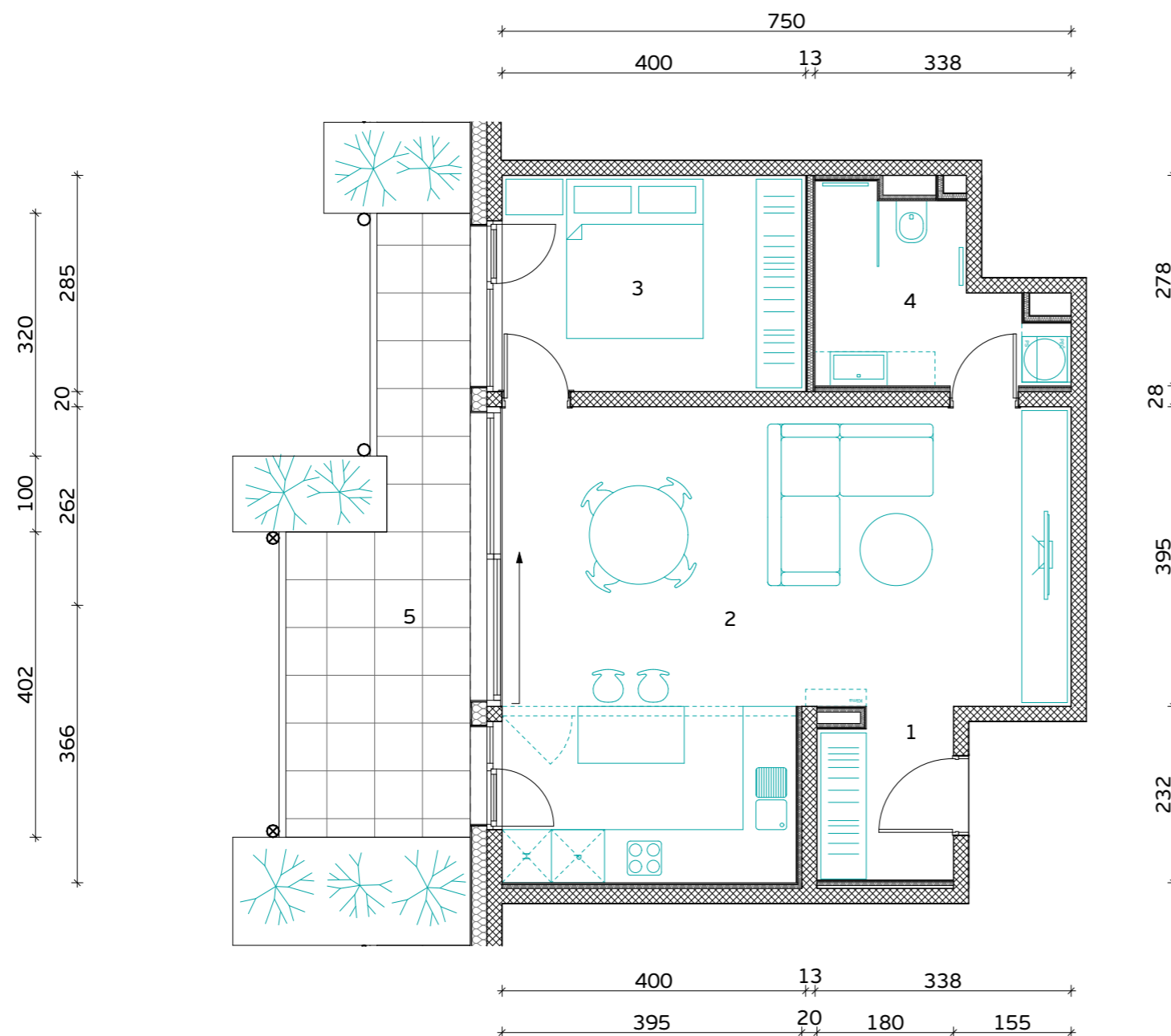
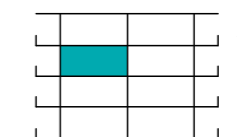

Položaj stanovanja v stavbi - prerez

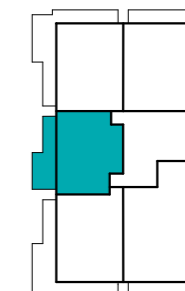

Položaj stanovanja v nadstropju - tloris

**STAVBA "B" - 2. NADSTROPJE**

**STANOVANJE B-2-3**

|                    |                     |
|--------------------|---------------------|
| 1. PREDPROSTOR     | 4.0 m <sup>2</sup>  |
| 2. BIVALNI PROSTOR | 38.7 m <sup>2</sup> |
| 3. SPALNICA        | 11.4 m <sup>2</sup> |
| 4. KOPALNICA       | 6.6 m <sup>2</sup>  |

**STANOVANJSKA POVRŠINA** **60.7 m<sup>2</sup>**

|                         |                     |
|-------------------------|---------------------|
| 5. TERASA (NADKRITA)    | 14.6 m <sup>2</sup> |
| 6. SHRAMBA ZA KOLESARJE | 5.5 m <sup>2</sup>  |

**SKUPNA POVRŠINA** **80.8 m<sup>2</sup>**

PARKIRNO MESTO 1 PM

VIŠEČI VRTOVI 8.8 m<sup>2</sup>



**PRVAHIŠA**

Družba za razvoj nepremičninskih projektov

INVESTITOR: **JURČKOVO NASELJE d.o.o.**

PRODAJALEC: **PRVA HIŠA d.o.o.**

Bravničarjeva ulica 13, 1000 Ljubljana

+386 (0)1 292 65 00

info@prvahisa.si

www.jurckovo-naselje.si

MERILO

