

MERILO

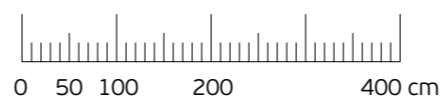

Komercialna skica in vrisana stanovanjska oprema sta informativne narave. Investitor si pridruzuje pravico do sprememb, ki ne vplivajo na funkcionalnost stanovanj.

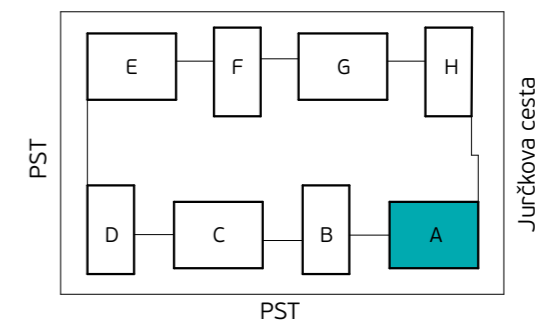

Skica naselja

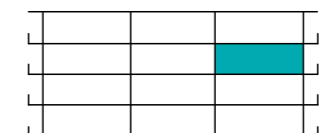

Položaj stanovanja v stavbi - prerez

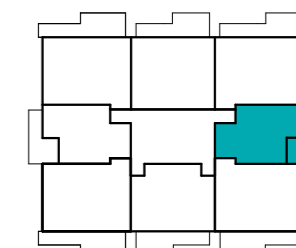

Položaj stanovanja v nadstropju - tloris

STAVBA "A" - 2. NADSTROPJE

STANOVANJE A-2-8

1. PREDPROSTOR	3.6 m ²
2. BIVALNI PROSTOR	26.1 m ²
3. SPALNICA	14.0 m ²
4. KOPALNICA	6.5 m ²

STANOVANJSKA POVRŠINA 50.2 m²

5. TERASA (NADKRITA)	9.0 m ²
6. SHRAMBA ZA KOLESIA	3.7 m ²

SKUPNA POVRŠINA 62.9 m²

PARKIRNO MESTO 1 PM

VISEČI VRTOVI 0.0 m²



PRVAHIŠA

Družba za razvoj nepremičninskih projektov

INVESTITOR: **JURČKOVO NASELJE d.o.o.**

PRODAJALEC: **PRVA HIŠA d.o.o.**

Bravničarjeva ulica 13, 1000 Ljubljana

+386 (0)1 292 65 00

info@prvahisa.si

www.jurckovo-naselje.si