

MERILO

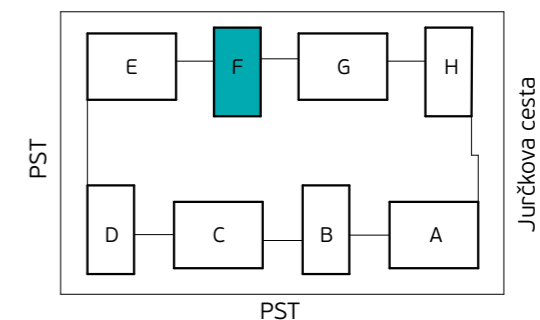

Komercialna skica in vrisana stanovanjska oprema sta informativne narave. Investitor si pridruzuje pravico do sprememb, ki ne vplivajo na funkcionalnost stanovanj.



Skica naselja

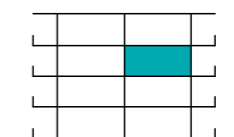

Položaj stanovanja v stavbi - prerez

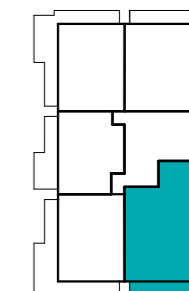

Položaj stanovanja v nadstropju - tloris

STAVBA "F" - 2. NADSTROPJE

## STANOVANJE F-2-1

1. PREDPROSTOR	7.4 m <sup>2</sup>
2. BIVALNI PROSTOR	35.5 m <sup>2</sup>
3. SPALNICA	13.9 m <sup>2</sup>
4. KABINET 1	9.3 m <sup>2</sup>
5. KABINET 2	8.9 m <sup>2</sup>
6. KOPALNICA 1	5.3 m <sup>2</sup>
7. KOPALNICA 2	5.2 m <sup>2</sup>

**STANOVANJSKA POVRŠINA** **85.5 m<sup>2</sup>**

8. TERASA (NADKRITA)	35.3 m <sup>2</sup>
9. SHRAMBA ZA KOLESA	8.3 m <sup>2</sup>

**SKUPNA POVRŠINA** **129.1 m<sup>2</sup>**

PARKIRNO MESTO 2 PM

VIŠEČI VRTOVI 13.0 m<sup>2</sup>



**PRVAHIŠA**

Družba za razvoj nepremičninskih projektov

INVESTITOR: **JURČKOVO NASELJE d.o.o.**

PRODAJALEC: **PRVA HIŠA d.o.o.**

Bravničarjeva ulica 13, 1000 Ljubljana

+386 (0)1 292 65 00

info@prvahisa.si

www.jurckovo-naselje.si